



OPERATION AND MONTAGE MANUAL

ROOF FANS

RFHT

Venture Industries Sp. z o.o. is not responsible for any damage caused by improper use of the fan and reserves the right to modify this document without informing the user.

INTRODUCTION

This manual covers fans in standard version, listed on the title page and it is source of information necessary for safe and proper use. Read this manual carefully before any use of the device, comply with its requirements and keep it in place with easy access for users and service. In case of any doubts about use of the fan, please contact with manufacturer.



After receiving the device - check

- whether the device is in compliance with order,
- whether the data on the rating plate are the same as desired (voltage, frequency, etc.)
- whether fan was not damaged during transport (e.g. there are no dents/cracks, impeller rotates freely)
- whether motor documentation (including operation manual) has been attached to the fan

In case of any irregularities, contact with your dealer or Venture Industries Sp. z o.o. service.

1. GENERAL INFORMATION

1.1 Information about device

- The fan is a not completed machine within the meaning of the Machinery Directive 2006/42/WE (please refer to the manufacturer's declaration – Appendix E).
- Fan is designed for use by trained, qualified adult persons. The fan is not designed for household and similar use.
- **The device is designed to transport clean air or air with low level of contamination.** Do not transport the explosive mixtures, liquids, viscous substances, substances with high humidity, substances that cause erosion, solid elements, and chemically reactive. The minimum temperature of transported medium is -20°C, maximum temperature is specified on the fan nameplate (for standard operation mode).
- The fan is designed for outdoor use. It must be protected from effects of lightning. The fan surroundings cannot contain explosives atmospheres, substances causing abrasion, chemically aggressive substances and viscous substances. The minimum temperature of transported medium is -20°C, maximum temperature is specified on the fan nameplate (for standard operation mode). The fan is not designed to operate near hot fume.
- The device must not be exposed to radiation (such as microwave, UV, laser, x-ray).
- The impeller of the fan has been balanced in conformity with minimum G6.3 class, according to ISO 1940-1, and entire fan with cat. BV-3 according to ISO 14694
- Details of fan construction have been included in appendix A
- Additional information on usage of the fan have been indicated on the device as markings. More information is introduced on appendix B.

1.2 General risk and guidelines

During entire fan life cycle pay particular attention to **the risk and guidelines** presented below:

1.2.1 Mechanical risk and guidelines

- The fan has moving elements (e.g. impeller). Do not use the fan without installed proper protection structures (e.g. guards on inlet and outlet) protecting from contact with moving elements. Prevent from opening the fan by unauthorized persons
- The fan has high suction power. Clothing, hair, assembly elements, items, and even body elements can be easily sucked in. Make sure that before start and during operation of the fan, near the fan inlet there is no person and items which can be sucked. It is forbidden to approach the fan in "loose" clothing or reaching toward inlet of working fan. Use appropriate inlet covers and if necessary – use relevant protective clothing (e.g. headgears).



Warning: Risk of serious injury.

- The air at the outlet of the fan has high energy. Elements sucked or placed inside the fan can be thrown with a high speed. In case of damage or improper operation, parts (with high kinetic energy) can be thrown out from fan. It is forbidden to look into the fan reaching toward inlet and outlet of the working fan. Make sure that before start and during operation of the fan there is no person on inlet side and in stream of transported medium. Do not use fan without proper safety constructions, inlet and outlet covers.
- During manufacturing the fan sharp edges was grinded. However the fan may have edges touching which may cause injury. We recommend the use of relevant protective gloves.
- Conveying equipments and fan support structures must be selected proper to the fan weight and ensure that fan would not move. Do not approach the hanging load during transport.
- The fan has a high inertness. In case of no permanent fix turning on the fan will lead to its uncontrolled movement. The unit can work only after proper installation.
- Uncontrolled start of the fan can create hazard situation. Prevent against unexpected start of the fan – see also 1.2.6.

1.2.2 risk and guidelines related with noise

- The sound pressure level is not the same over the fan whole range. We recommend to check the sound pressure level and if necessary use the silencer and relevant sound protection.

1.2.3 risk and guidelines related with used materials

- In case of fire or transport of improper medium – fan parts can generate fumes hazardous to health. See also 1.2.5.

1.2.4 risk and guidelines related with environment

- The fan can make over and under pressure. In areas where a specified air pressure and the quantity of air are required (eg. in places with combustion) make sure that there would be no deficit/excess of air. Ensure that the installation to which the fan is connected withstand the under/over pressure which can be made by fan (including work with forbidden parameters).

1.2.5 risk and guidelines related with temperature

- The housing and fan elements are not insulated and take the temperature of the transported medium. During transport the temperature of medium and fan components may increase. Electric motor may heat up to high temperatures (especially when overloaded/overheated – cased

by eg. blocking the impeller, too low supply voltage, too high medium temperature). The appropriate steps should be made to prevent from fire and burns caused of high temperatures.

In case of fire – to extinguish a fire use fire extinguisher approved for electrical equipment and follow recommendation of fire department.

1.2.6 risk and guidelines related with electricity and unexpected start/ connecting power supply

- Before any work on the fan (e.g.: installation, maintenance and review, dismantling) the power supply must be completely disconnected (all poles, check there is no voltage, disconnecting switch with minimum 3mm insulation gap).
- Make sure that power supply won't be connected during the work on the unit, and that the moving parts do not move. It is recommended to wait 3 minutes after disconnecting unit before open the fan cover.



Warning: risk of electric shock.

- The appropriate steps should be made to prevent from electric shock. Protect from getting access to the electric elements by unauthorized person.
- Fan is not equipped with control system which blocks restart after a power shutdown or failure – the return of power supply cause in immediate start. Make sure that there will not be any dangerous and forbidden situation in case of temporary power supply failure.
- The built-in motor regulator protection turns off fan only during the failure. This protection after tripping (e.g. caused by motor temperature overload) resets automatically (e.g. after cooling down motor temperature). Make sure that there won't be any dangerous and forbidden situation after tripping motor protections.
- In case of blocking the impeller –release of impeller can provide to sudden movement. Take appropriate steps to prevent form blocking impeller, and in such case turn off power supply and review the fan (see chapter 5).
- After disconnecting power supply the fan rotating parts are still rotating for period of time under the accumulated energy. Take it into account when using the fan.

1.2.7 risk and guidelines related with use

- Improper installation and use may lead to damage of the device and to the dangerous situation. The unit can be installed, maintained, dismantled and used only by qualified and authorized personnel, in accordance to safety rules and current regulations in the country of use (including proper electrical authorization). Personnel need to be familiar with reactions of the fan.
- If it is necessary to remove parts of the unit (e.g. during montage or maintenance), users must be warned about the potential risk, and these parts of unit must be closed/mount after the completion of the work. It is forbidden to use the unit if it is incomplete / disassemble.



Warning: Risk of serious injury.

- The device must not be exposed to radiation (such as microwave, UV, laser, x-ray).
- Any modifications of the unit are forbidden. Complicated maintenance work (such as dismantling the motor or impeller) need to be made by Venture Industries Sp. z o.o. service or with it permission. Improper assembly may lead to reduce the fan parameters, damage the unit and lead to the dangerous situation.

1.2.8 risk and guidelines related with explosive atmospheres

- Contact of the fan with explosive atmospheres could cause the ignition. It is forbidden to storage or use the fan with explosive atmospheres inside or outside the unit.

2. TRANSPORT AND STORAGE

During transport and storage follow the guidelines contained in 1 chapter and **transport and storage guidelines**.

2.1 transport and storage guidelines

- The fan should be transported and stored in original packaging, without excessive shocks. The device must be protected from weather conditions, transported and stored in dry, well ventilated, and free from substances harmful to the device areas. The fan cannot be transported and stored in areas with fertilizers, chlorinated lime, acids and other aggressive chemicals. Fan should be protected against foreign body entrance.
- During transport and storage protect the fan against damage (including crush).
- The unit of size 355 and below should be lifted by the base. The unit of size 400 and above should be lifted by elements designed for it (according to Fig. 1). Do not lift the unit by motor elements, wires, etc. **During lifting the unit must remain stable.**

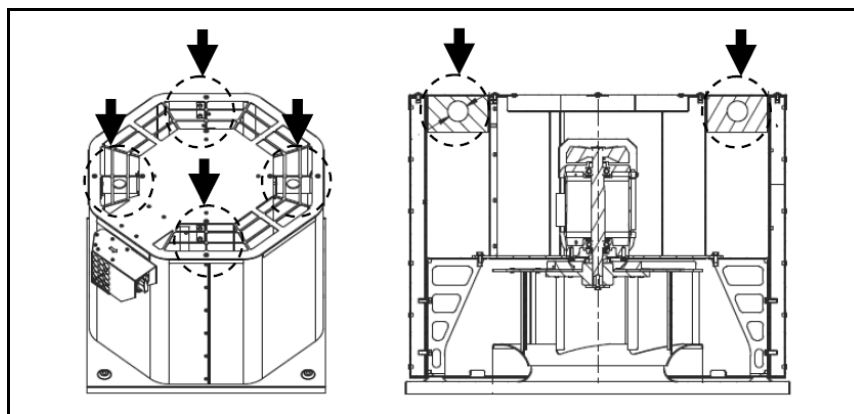

- Do not come beneath lifted unit. When cables break, falling unit could cause serious injury or death.
- It is recommended that storage time not exceed one year. After long storage, check the fan. (chapter 5). It is recommended to once a month manually rotate the impeller (at least 3 rounds).

3. MONTAGE AND INSTALLATION

During installation follow the guidelines contained in 1 section of this instruction and **installation guidelines**.

3.1 installation guidelines

- The fan is a machine not ready for use (within the meaning of the Machinery Directive 2006/42/WE - before use ensure conformity with requirements of Machinery Directive 2006/42/EC and current editions (with changes) of: EN ISO 12100, EN ISO 13857, EN 349+A1, EN ISO 13850, EN 60204-1.
- Before installation remove temporary items that protect fan during transport and storage (e.g. box, foil, caps – do not remove any guards) – Starting the fan with those items could lead to damage of the fan. Make sure that the fan is not damaged.
- The device must be mounted in the horizontal orientation with cover on top, in accordance with drawing below (the arrows show the air flow direction). The fan needs to be mounted to external constructions (we recommend use of dedicated roof stand) with use all montage holes placed on the fan base. Due to the use of the fan outdoor – prevent form leakage of water between the fan base and montage construction by proper sealing.

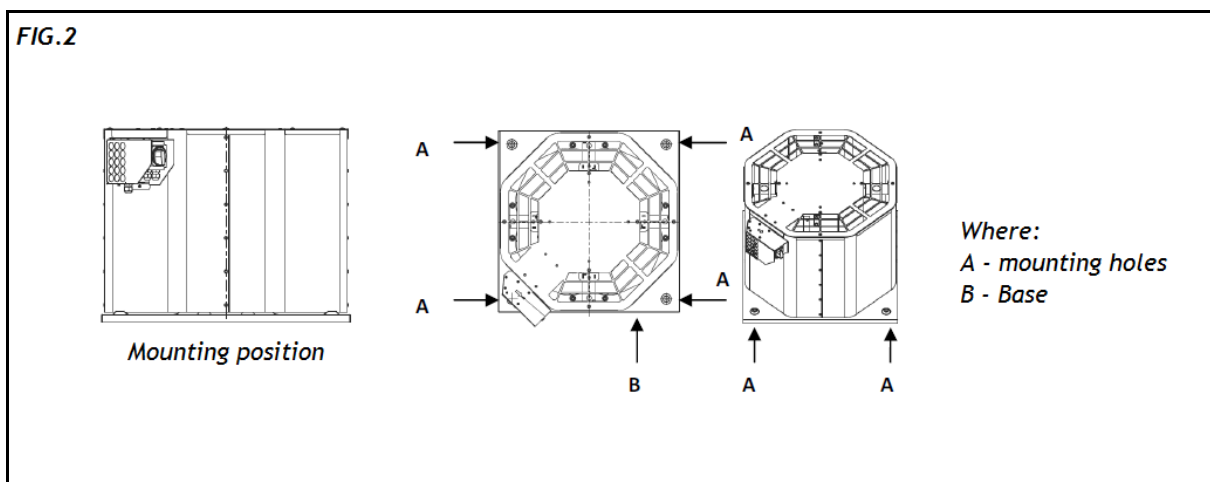

- The fan support construction must be able to support the fan working with the full power (start-up, breakdown, improper use should be also consider). For installation use connecting elements secured against self-loosening.
 - Install proper protective structures, grids (inlet, outlet, moving parts), if not mounted by manufacturer. Open inlet of the fan need to be protected proper by proper grid.
- Note:** Although normally used shields the device should be installed in such a way that prevent from getting access to the device (rotor) from the outlet.
- It is recommended to use accessories to minimize the vibration transmitted from/to the fan.
 - It is recommend to provide the distance of 3 inlet dimensions of clearance between inlet and any obstructions (such as filters, bends, wall) and distance guaranteeing free air movement.
 - After fan mechanical installation make all electrical connections and check the impeller direction of rotation in accordance with points 3.2 and 3.3.
 - Ensure that there are no foreign bodies (eg. mounting elements, tools) inside and near of the unit, that impeller is not blocked, the fan is properly secured after installation (the cover is closed and secured, the terminal box/service switch is closed, the fastening elements are properly tightened).

3.2 electrical connection guidelines

- The fan and power supply network must be secured in accordance with local law requirements.
- Use protection agianst short circuits, overloads and for fans with three phase power supply - voltage failure/unbalance. The protection need to be appropriate to the nominal fan current (see fan nameplate) and starting fan current.
- The electrical connection need to be made in accordance with the data on the fan and motor nameplates, wiring diagram and fan marking.
- Use appropriate protection against electric shock - it is required to connect fan grounding terminal placed inside connection box to proper grounding system.
- Use electrical wires with proper insulation and size. Wires should be placed in way that in any situation will not touch the moving elements, and that the water (eg. from condensation) not flow inside the junction box. Wires should be connected to the terminal box, through properly tightened cable glands and wire fasteners.

3.3 rotor rotation direction

Make sure that after end of installation and when using the fan the impeller would rotate in correct direction. After mounting fan to the proper construction turn on fan for 1 sec. and check the impeller rotation direction and generates air flow in correct drection. The checking motor direction should be made in accordance with chapter 1 and 4 and with caution.

The work with impeller rotating in the wrong direction reduces fan parameters and may damage it. In case of improper impeller rotation turn off the power supply, wait until impeller stops to move, and change proper wires in the terminal box (three phase power supply), contact with manufacturer (single phase power supply fan).

4. USE

During fan use follow the guidelines contained in 1 section of this instruction and **use guidelines**.

Before first start of the fan follow guidelines from chapter 5.

4.1 use guidelines

- Make sure that turning on of the fan does not make any risk for personnel and property.
- Fan cannot work with voltage, frequency, current higher than shown on the fan nameplate.
- The fan is designed for continuous operations (S1) – too high frequency of turning may lead to the motor regulator overheat and damage (see also chapter 4.2 Guidelines for regulation).
- **The fan is not adapted to rotation speed regulation.** Power supply parameters (voltage, frequency) have to be equal with those indicated on the nameplate.
- In case of activation of any electrical protection, detection of damage, working with current greater than specified on the fan nameplate – unit must by immediately turn out off use.
- The device is adapted to work in certain range of characteristic. Too high volume flow rate of medium, start/work of device with completely closed inlet and/or outlet may lead to motor overheat caused by current consumption exceeding value on the rating plate (current consumed by fan grows as resistance of installation grows)

5. MAINTENANCE, REVIEW

During maintenance and review follow the guidelines contained in 1 chapter of this instruction and maintenance guidelines.

5.1 maintenance guidelines

- Fan must be subject of regular review and maintenance (point 5.2). The set between routine checks and maintenance should be determined by user, based on the observation of unit and specific conditions and actions. If irregularities are found, the device must be taken out of service and repaired.
- To clean fan use slightly damp delicate material. It is prohibited to use detergents, liquids under pressure and tools that may scratch the unit surface. After fan cleaning (after end of maintenance) turn on the fan for 30 minutes (with full speed).
- In case of long fan downtimes it should be run at least once per month for 2 hours (with full speed).
- Prevent the accumulation of dust/dirt on and inside the fan. Dirt accumulated on: grids – may reduce the fan parameters; impeller – may lose it balance; housing and motor – can reduce the cooling; hot surfaces – in extreme situations may ignite. If the device is secured by filter - filter should by regularly inspected and replaced if it pollution is too high. The dirt accumulated on the filter reduces the fan parameters.
- Ensure that there are no foreign bodies near and inside the fan, the impeller is not blocked, the unit is clean, dry and secured after maintenance and review.
- Fan motor is equipped with bearing with life expectancy 40 000 hours (ambient temperature 40°C). Bearings do not need refill lubricate.

5.2 Unit maintenance and review

During review and before first use of the unit or after long time period of storage attention to the following should be paid:

- accumulation of the dirt on the unit and filter (if used), state of grid / covers,
- is the device stable, not damaged, the structure is complete, moving elements can move freely,
- if there are any foreign bodies or loose elements inside the fan,
- if there is loose bearing and rotating the shaft cause in its heavy/noisy work,
- are connecting elements tightened, is fan surface without corrosion, are electrical wires not damaged,
- is the safety equipment working and property set, is shock protection effective,
- if there are leaks from the motor, overheating and vibrations.

During operations, especially after first start pay attention to:

- correct operation,
- there are no unusual noises and vibrations, leaks from the motor, overheating or vibrations,
- the grids are in proper condition,
- the fan current is not higher than show on nameplate. Exceed of current placed on the name plate could by a sign of unit damage.

6. REPAIR, WARRANTY

Use only original spare parts and original accessories. Fan repairs need to be made by manufacturer or after manufacturer permission.

Warranty conditions are placed in the fan warranty card.

7. DISMANTLING AND RECYCLING

Disconnect unit from its power supply, and dismount according to the guidelines from section 1 of this instruction. Therefore, please deposit all left-over material and packaging in their corresponding recycling containers and hand in the replaced machines to the nearest handler of this type of waste product.

APPENDIX A - (SCHEMATIC DIAGRAM OF THE FAN / LIST OF DEVICES)

1. General overview

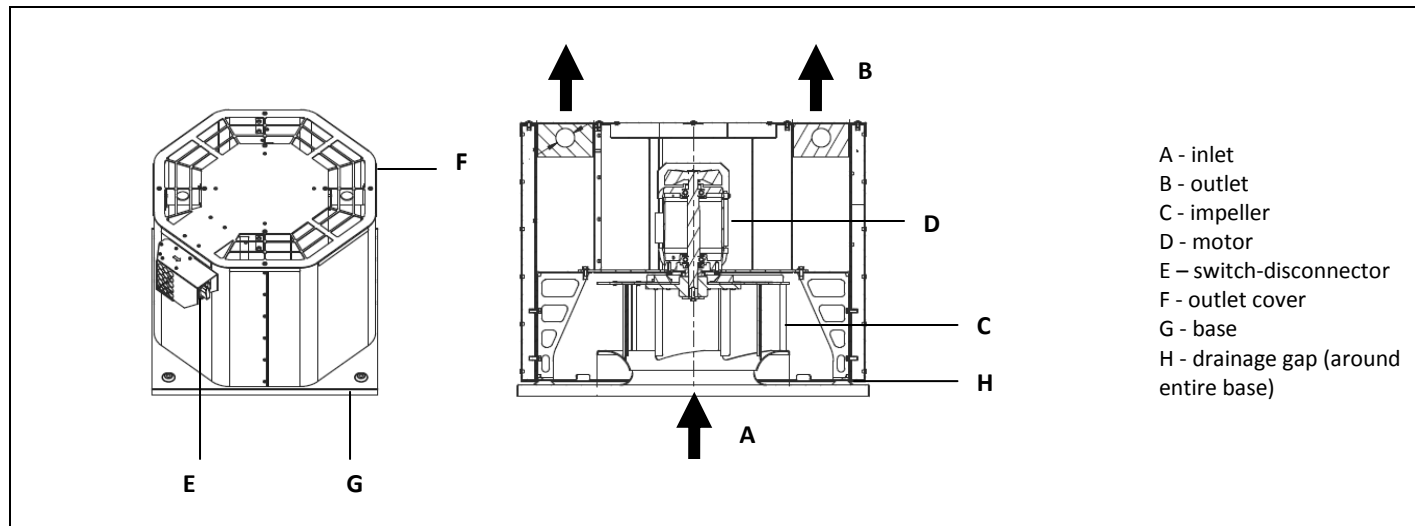

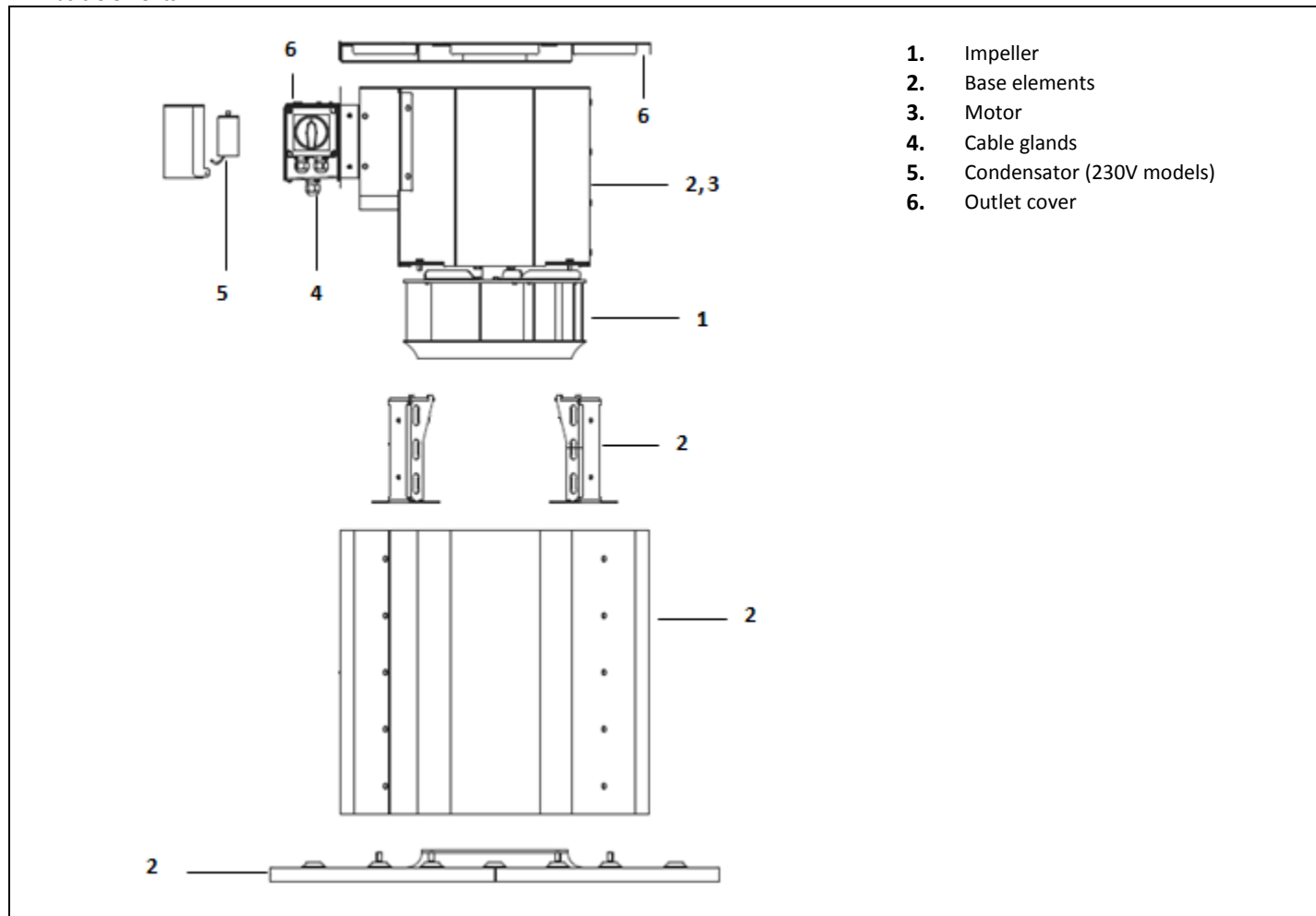

2. Basic elements



Base elements (2, 6) made of galvanized steel sheet or aluminium. Impeller (1) made of painted steel, galvanized steel sheet and steel and aluminium elements. Fasteners made of aluminium, steel, galvanized steel and stainless steel have been. The fan has been sealed with PTFE sealings and silicon. Additionally, the base has been sound-proofed with insulation mat.

Detailed information on applied componenets and tighten torques (not applicable to motor) have been attached to following manual oraz are available on request.

APPENDIX B - (PRODUCT INDICATION)

		www.venture.pl www.ventur.se www.ventur.fi www.venturdeutschland.de VENTUR TEKNISKA AB VENTUR FINLAND OY VENTUR DEUTSCHLAND GmbH			
[1]					
Motor	[2]	[3] kW	[4] A	IP	[5]
[6] V	[8] Hz	[9] rpm	Ins. class [10]		
Weight	[11] kg	Temp. ambient max.	[12] °C	Temp. max.	[13] °C
[14]					
No.:	[15]	Art. No.: [16]			

[1] – product full name

[2] – motor type

[3] – motor power

[4] – nominal current

[5] – motor IP class

[8] – nominal voltage

[8] – power supply frequency

[9] – nominal fan speed

[10]- motor insulation class

[11] - weight

[12] – max ambient temperature

[13] – max temperature of transproted medium

[14] – informetion of accordance with ErP Directive (if apply)

[15] – serial number

[16] – Art. No.

Additional information indicated on the device

- arrow informing about correct direction of impeller rotation

- indications related to safe use of device



HIGH
TEMPERATURE

UWAGA!



DO NOT TOUCH

DANGER!

DO NOT TOUCH - UNIT WITH HOT SURFACE. HIGH RISK OF BURNING
KEEP UNIT AWAY FROM OTHER OBJECTS - HIGH RISK OF FIRE

APPENDIX C - (RECEIPT FORM)

Before launch	Check confirmation
Type and model of fan are in accordance with the order.	
The fan is undamaged.	
There is no foreign body inside fan and the fan is clean.	
The fan is reliably and solidly fixed in workplace.	
The fan is properly levelled	
Wires are properly tightened.	
Ambient temperature and transported medium temperature are compatible with fan nameplate	
Proper electrical protection is applied	
Grounding of fan is applied.	
Mains supply is compatible with fan power supply.	
Power supply disconnecting switch (with 3mm visible gap) is applied.	
Personnel using the fan read and understood the operation and montage manual.	
Proper inlet and outlet covers (grids) have been applied	
After fan launch (continuous work period minimum 30 minutes)	
Readings and set of vibration measurement device has been written (they are available in future)	
Value of current for each of phase does not exceed nominal one	
The vibration value is not higher than permitted.	

APPENDIX D - (EXAMPLES OF DEVICE FAULTY WORKING)

SYMPTOMS	POSSIBLE REASON
Excessive vibration or noise	<ul style="list-style-type: none"> •Used or damaged impeller •Fan levelled in wrong way •Dirt accumulated on impeller caused loss of balance; •Impeller loss of balance •Parts rubbing; •Damage or wear of bearings; •Damage of measurement system, that is responsible for signalization of excessive vibration. •Deformed motor shaft; •Loose of impeller fix screw, impeller is loose on motor shaft; •Loss of balance of motor impeller or damage of motor (wear/damage of bearing)
Motor overload	<ul style="list-style-type: none"> •Rubbing between fan impeller and housing; •Damage or wear of bearings; •Damage of motor windings (overheat, insulation degradation, insulation breakdown etc.); •Damage of switch or security system; •Failure of one of supply phases; •Exceeding of maximum motor speed; •Too low flow
Failed fan start-up	<ul style="list-style-type: none"> •Rubbing between fan impeller and housing or foreign body (e.g. tool left after installation); •Failure of one of supply phases; •Failure of start-up system, e.g. Y/D •Reset of security devices has not been made, wrong security device •Motor connected in wrong way or damaged •Too low supply voltage
Protective devices activation during fan work and overheating	<ul style="list-style-type: none"> •Excessive start-up time •Motor overload •Motor launching done too often (thermal protection – if applied or overheating) •Improper set of protection system e.g. in system with PTC or thermocontact sensors (if applied) •Improper cross-section of power supply wires •Lack of sufficient motor cooling eg. dirt placed on motor cooling impeller (thermal protection – if applied or overheating)
Too low flow	<ul style="list-style-type: none"> •Damage of device •Too low power supply frequency •Obstacles in ventilation installation

APPENDIX C - DECLARATION OF MANUFACTURER

EU Declaration of Conformity in accordance with 2014/30/EU Directive

EC Declaration of Conformity in accordance with 2006/42/EC Directive

Manufacturer:

Venture Industries Sp. z o.o.
ul. Mokra 27
05-092 Łomianki-Kielpin
Polska



doc. no. R2.1.02012019_EN

declares that the product described below:

Name: Roof fan
Type: JET / MPB-R / GMT-R / RBH / RVISP / RFHT
Model: all manufactured
Serial no.: all manufactured
CE marking date: 2010 / 2016 (GMT-R / RHFT)
Use/Function: transport of specified medium **after incorporation into machinery/installation**

complies with the requirements of:

- Machinery Directive 2006/42/EC
- Electromagnetic Compatibility Directive 2014/30/UE

Compliance with 2014/30/EU Directive applies to the single product. When product is used with other components the installer is responsible for compliance of entire system with the provisions of 2014/30/EU Directive.

Following standards were applied (partially or full):

EN ISO 12100 EN 60034-1 EN 60204-1 EN ISO 13857

Compliance with EN ISO 13857 refers to safety devices supplied and installed in the product by the manufacturer.

Furthermore:

- The machinery into which the product is incorporated must particularly meet the requirements of current standards: EN ISO 12100, EN ISO 13857, EN 349+A1, EN ISO 13850, EN 60204-1. It is required to apply adequate protection (e.g. shield) from inlet side to prevent from contact with impeller.
- Product is in conformity with the Commission Regulation (EU) No 1253/2014 implementing ErP Directive 2009/125/EC with regard to eco-design requirements for ventilation units.
- The person authorized to comply the relevant technical documentation: *Piotr Pakowski (Lotnicza 21A, 86-300, Grudziądz, Poland).*
- Quality system is in accordance with ISO 9001:2015.

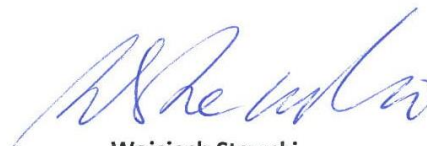

Wojciech Stawski
Managing Director

Date: 02.01.2019
Kielpin